

Project : South Pars Field Development (Phases II & III)

Customer : Hyundai Eng. & Con. Co., Ltd.

Order No. ATS-2760M-L-0023

Job No. 99012

Scan No. 761

NOTES: VALVE PROFILE MAY VARY

HINGE/STOP PINS MUST BE VERTICAL FOR HORIZONTAL FLOW

LIFTING EYEBOLTS WILL BE SUPPLIED FOR VALVES 6" AND LARGER

SERVICE FLUID : AF, BB, BW, CA, CH, CL, CW, DF

PIPING CLASS : B01, B03, B06, B10, B12

OPER. TEM.(MAX) : 200°C

ITEM	DESCRIPTION	MATERIAL	
		FORGE MATERIAL	CAST MATERIAL
BR01	BODY	ASTM A105	ASTM A216 WCB
B02	PLATE	SOLID STELLITE 6	
BR03	HINGE PIN	AISI316	
BR03	STOP PIN	AISI316	
B04	SPRING	INCONEL X750	
BR06	CARRIER	AISI316	
BR08	KEEPER PLATE	AISI 316	
BR10	RETAINING SCREW	AISI 316	
	BODY SEAT	STELLITE 6 OVERLAY	
	PLATE SEAT	AS PLATE	

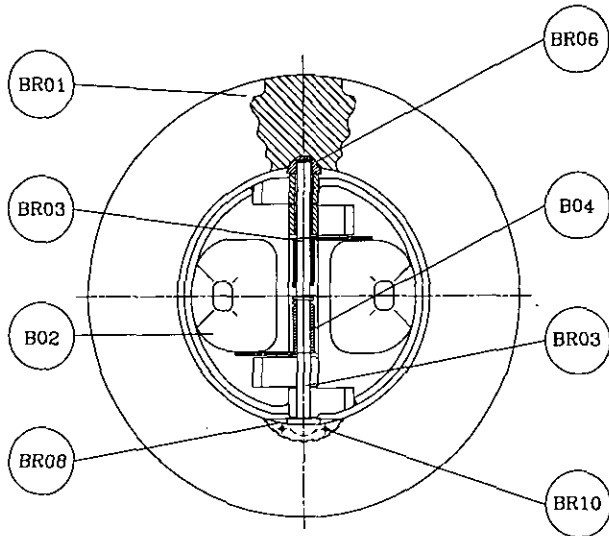

ITEM No.	TAG NUMBER	SIZE	CLASS	CASTING OR FORGING	DIM A (MM)	DIM B (MM)	DIM C (MM)	DIM E (MM)	STUD SELECTION					PROFILE	SPECIAL FEATURE
									No. OFF	DIA (INCHES)	LENGTH (MM)	WEIGHT (KG)			
8	VCD10131	2"	150lb	FORGING	104.8	60.3	-	57.2	4	0.625	152.4	3.2	F	None	
9	VCD10131	3"	150lb	FORGING	136.5	73.0	50.8	86.9	4	0.625	177.8	6.4	F	None	
10	VCD10131	4"	150lb	FORGING	174.6	73.0	88.9	113.0	8	0.625	177.8	9.5	F	None	
		6"	150lb	FORGING	222.3	98.4	139.7	165.6	8	0.75	209.6	16	F		
		8"	150lb	FORGING	279.4	127.0	171.5	206.5	8	0.75	247.7	36	F		
		10"	150lb	FORGING	339.7	146.1	235.0	260.4	12	0.875	279.4	52	F		
		12"	150lb	FORGING	409.6	181.0	260.4	300.2	12	0.875	311.2	97	F		
		14"	150lb	CASTING	450.9	184.2	285.8	338.8	12	1	330.2	123	c		
		16"	150lb	CASTING	514.4	190.5	331.8	387.4	16	1	342.9	133	c		
		18"	150lb	CASTING	549.3	203.2	395.3	438.2	16	1.125	368.3	141	c		
		20"	150lb	CASTING	606.4	219.1	438.2	487.4	20	1.125	384.2	215	c		
		24"	150lb	CASTING	717.6	222.3	536.6	578.6	20	1.25	412.8	358	c		
		26"	150lb	CASTING	774.7	355.6	596.9	629.4	24	1.25	587.4	680	c		
		28"	150lb	CASTING	831.9	381.0	647.7	680.2	28	1.25	619.1	544	c		
		30"	150lb	CASTING	882.7	304.8	641.4	734.8	28	1.25	533.4	662	c		
		32"	150lb	CASTING	939.8	355.6	641.4	784.1	28	1.5	625.5	707	c		
		36"	150lb	CASTING	1047.8	368.3	647.7	864.6	32	1.5	657.2	682	c		

RAISED FACE STOCK FINISH TO ASME B16.5 250 TO 500 AARH

VALVES 2" TO 24" FIT BETWEEN ASME B16.5 FLANGES

VALVES 26" AND ABOVE TO FIT BETWEEN ASME B16.47 SERIES A FLANGES

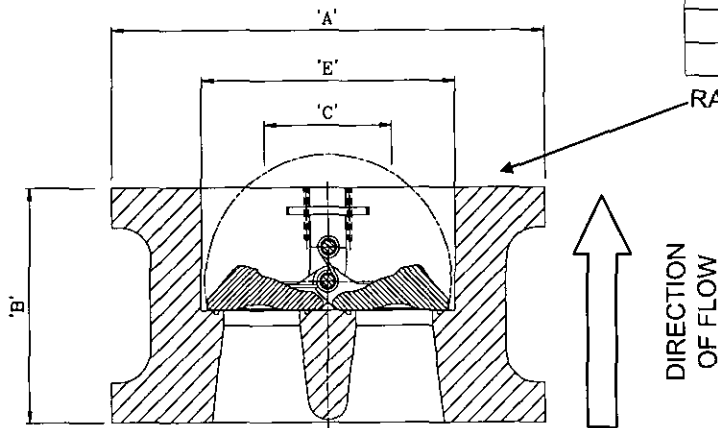

Goodwin International			THIS IS THE PROPERTY OF GOODWIN INTERNATIONAL LTD. AND MUST NOT BE REPRODUCED WITHOUT WRITTEN PERMISSION		
TITLE WAFFER TYPE CHECK VALVE			PROJECTION 3RD		
SCALE	DRAWN PQ	PROJECTION 3RD	REV	SIZE	
VALVE CODE BR-015-CUUPS-YS	CHECKED VA	DATE 11-Apr-00	AM12862-2	2	A3